



Semester 1 Examination 2012

Question/Answer Booklet

MATHEMATICS 3CD

**Section Two:
Calculator-assumed**

Name of Student: _____

Name of Teacher(circle) Kirou Menzies Hoy Orton Sanders

Time allowed for this section

Reading time before commencing work: 10 minutes
 Working time for this section: 100 minutes

Materials required/recommended for this section

To be provided by the supervisor

This Question/Answer Booklet
 Formula Sheet (retained from Section One)

To be provided by the student

Standard items: pens, pencils, pencil sharpener, eraser, correction fluid/tape, ruler, highlighters
 Special items: drawing instruments, templates, notes on two unfolded sheets of A4 paper, and up to three calculators satisfying the conditions set by the Curriculum Council for this examination

Important note to students

No other items may be used in this section of the examination. It is **your** responsibility to ensure that you do not have any unauthorised notes or other items in the examination room. If you have any unauthorised material with you, hand it to the supervisor **before** reading any further.

Structure of this paper

Section	Number of questions available	Number of questions to be answered	Working time (minutes)	Marks available	Percentage of exam
Section One Calculator-free	6	6	50	50	
Section Two Calculator-assumed	12	12	100	100	
			Total	150	100

Instructions to students

- 1 Write your answers in the spaces provided in this Question/Answer Booklet. Spare pages are included at the end of this booklet. They can be used for planning your responses and/or as additional space if required to continue an answer. If you need to use the space to continue an answer, indicate in the original answer space where the answer is continued. i.e. give the page number. Fill in the number of the question(s) that you are continuing to answer at the top of the page.
- 2 **Show all your working clearly.** Your working should be in sufficient detail to allow your answers to be checked readily and for marks to be awarded for reasoning. Incorrect answers given without supporting reasoning cannot be allocated any marks. For any question or part question worth more than two marks, valid working or justification is required to receive full marks. If you repeat an answer to any question, ensure that you cancel the answer you do not wish to have marked.
- 3 It is recommended that you **do not use pencil**, except in diagrams.

QUESTION	MARKS AVAILABLE	MARKS GAINED
7	10	
8	7	
9	10	
10	7	
11	7	
12	9	
13	8	
14	9	
15	11	
16	7	
17	9	
18	6	
TOTAL	100	

Section Two: Calculator-assumed

(100 marks)

This section has **twelve (12)** questions. Answer all questions. Write your answers in the spaces provided.

Working time: 100 minutes

Question 7

(10 marks)

- (a) Emily is a very strong soccer player who has a probability of $\frac{3}{5}$ of scoring a goal with each attempt. She has 15 attempts. Find the probability that the number of goals she scores is less than 7. (2)

- (b) Suppose that Y is distributed normally with unknown mean μ and standard deviation σ . Given that $P(\mu - 25 \leq Y \leq \mu + 25) = 0.9$, find the value of σ . (2)

Question 7 (continued)

- (c) The West Coast Eagles have a squad of 29 players. Only 22 players are selected to form a team. Cox and Shuey are members of the squad. How many different teams are possible if (6)
- (i) all players are available?
 - (ii) Cox must be included?
 - (iii) Shuey is injured and cannot play?
 - (iv) Cox will not be included but Shuey must play?
 - (v) Cox and Shuey must be included in the team?
 - (vi) Cox and Shuey will not be in the team together?

Question 8

(7 marks)

(a) It takes 12 hours to drain a storage tank by opening the valve at the bottom. The depth 'y' of fluid in the tank 't' hours after the valve is opened is given by $y = 6\left(1 - \frac{t}{12}\right)^2$ metres.

(i) Find the rate $\frac{dy}{dt}$ m/hour at which the tank is draining at time, t. (2)

(ii) When is the fluid in the tank falling fastest and slowest?

What are the values of $\frac{dy}{dt}$ at these times? (2)

Question 8 (continued)

- (b) If the volume of a cylinder is given by $V = 2\pi r^3$, find the appropriate percentage change in V when r changes by $\frac{1}{2}\%$ (3)

Question 9

(10 marks)

- (a) Give two reasons why the following cannot be a probability distribution. (2)

x	3	1	2	3	5	0
$P(X=x)$	0.0	0.1	0.4	0.1	0.2	0.3

- (b) The probability distribution of x where random variable, X is the sum of the uppermost numbers when two fair die are rolled is tabulated below.

x	2	3	4	5	6	7	8	9	10	11	12
$P(X=x)$	$\frac{1}{36}$	$\frac{2}{36}$	$\frac{3}{36}$	$\frac{4}{36}$	$\frac{5}{36}$	$\frac{6}{36}$	$\frac{5}{36}$	$\frac{4}{36}$	$\frac{3}{36}$	$\frac{2}{36}$	$\frac{1}{36}$

Find

(i) $P(X > 3)$ (2)

(ii) $P(X < 10 | X > 3)$ (2)

- (iii) If event A is $X > 3$ and event B is $X < 10$, are these two events independent? Justify your answer. (4)

Question 10

(7 marks)

(a) The function $f(x)$ is differentiable for all $x \in \mathbb{R}$ and satisfies the conditions

$$f'(x) < 0 \text{ where } x < 2$$

$$f'(x) = 0 \text{ where } x = 2$$

$$f'(x) = 0 \text{ where } x = 4$$

$$f'(x) > 0 \text{ where } 2 < x < 4$$

$$f'(x) > 0 \text{ where } x > 4$$

(i) Draw a sketch of this function $f(x)$. (3)

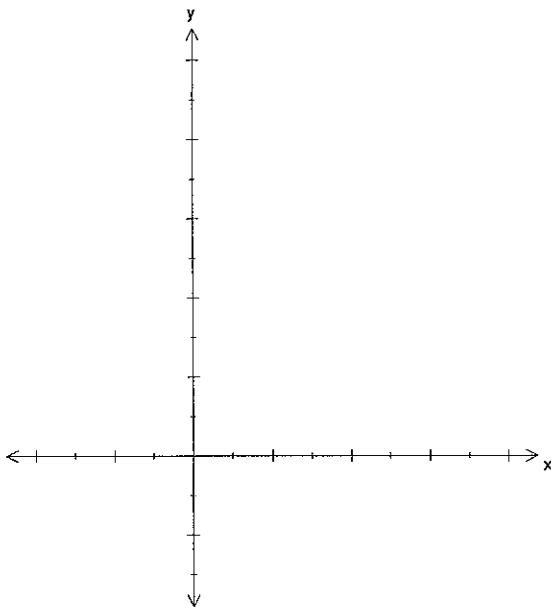

(ii) State whether the following statement is true or false.
 "The graph $f(x)$ has a stationary (horizontal) point of inflection where $x=4$ ". (1)

Question 10 (continued)

- (b) A uniform probability distribution is given below: (3)

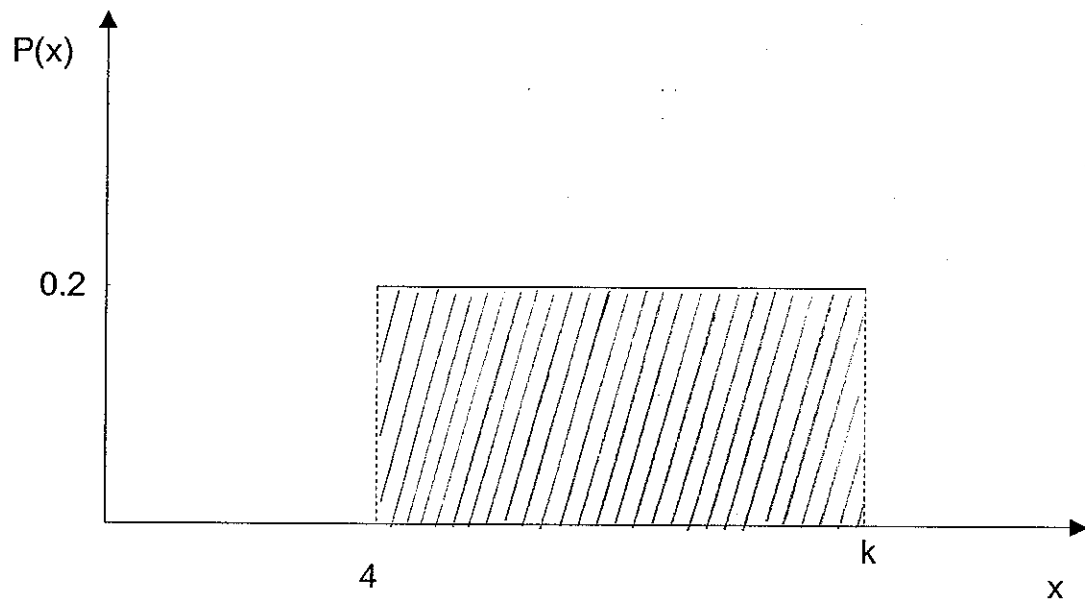

The equation of the horizontal line is $y = 0.2$.

- (i) find the value of k
- (ii) find $P(x \leq 8 \mid x \geq 5)$

Question 11

(7 marks)

- (a) The function $y = e^{x(x-1)(x+1)}$ is transformed to $y = -e^{x(1-x^2)}$.

Describe the transformation in order.

(3)

- (b) The curve C has equation $y = e^{-x^2}$ and is drawn below

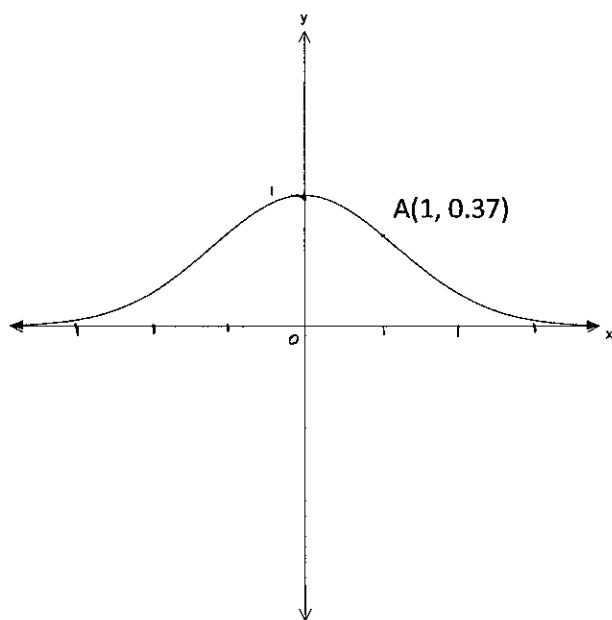

- (i) Sketch the graph of $y = f(-x+1)$.

(2)

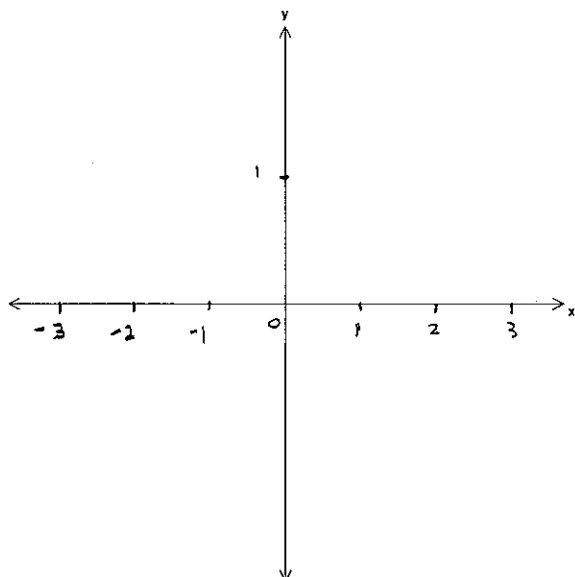

Question 11 (continued)

- (ii) State the coordinates of A if the curve is transformed to $y = -f\left(\frac{1}{2}x\right) + 2$

(2)

Question 12

(9 marks)

- (a) A company produces fruit balls coated in either dark chocolate or milk chocolate. A large number of these fruit balls are placed in a box. Twenty per cent of the fruit balls in the box are coated with dark chocolate.

(i) Calculate $C_4^{10} (0.2)^4 (0.8)^6$ (1)

- (ii) A random sample of ten fruit balls is taken from the box.
Explain the meaning of $C_4^{10} (0.2)^4 (0.8)^6$ with respect to this sample. (2)

(b) (i) Find n given that $C_0^n (0.2)^0 (0.8)^n = 0.167\ 772\ 16$ (1)

- (ii) Explain the meaning of your answer to part (b) with respect to the fruit balls. (2)

Question 12 (continued)

- (c) The curve $y = e^{2x}$ and $y = e^{-x}$ intersect at the point $(0, 1)$ as shown in the diagram. (3)

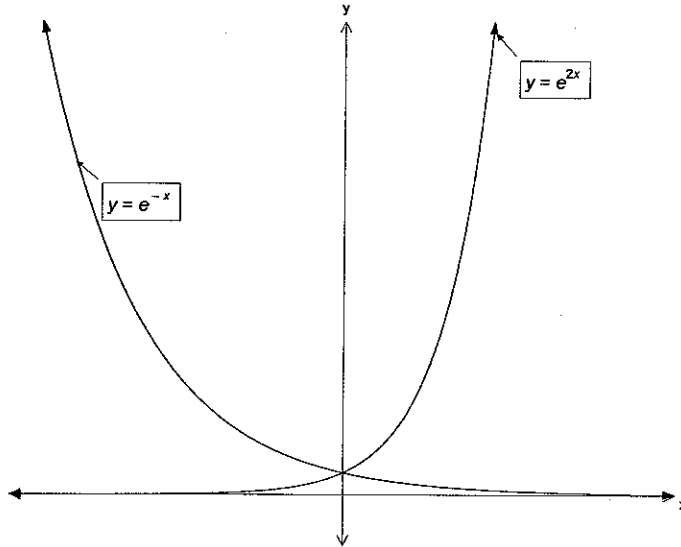

Find the area enclosed by the curves and the line $x=2$.
 Leave your answer in terms of 'e'.

Question 13**(8 marks)**

Adam paints garden gnomes to sell. He sends the garden gnomes to his father (a qualified quality controller) in the order of completion, who classifies them as either 'Superior' or 'Regular', depending on the quality of their finish.

If the garden gnome is Superior, then the probability that the next garden gnome is superior is 0.9.

If the garden gnome is Regular, then the probability that the next garden gnome is superior is 0.7.

- (a) If the first garden gnome inspected is Superior, find the probability that the third gnome is Regular. (2)

- (b) If the first garden gnome inspected is Superior, find the probability that the next three gnomes are Superior. (1)

- (c) A group of 3 consecutive garden gnomes is inspected and the first is a Regular. It is also found that of these three gnomes,

$$P(\text{no Superior}) = 0.09$$

$$P(\text{1 Superior}) = 0.28$$

$$P(\text{2 Superior}) = 0.63$$

- Find the expected number of these gnomes that will be Superior. (2)

Question 13 (continued)

- (d) Adam's little brother, Brodie joins in this business venture. The probability that any one of Brodie's painted garden gnomes is Regular is 0.8. He wants to ensure that the probability that he paints at least two Superior is at least 0.9. Calculate the minimum number of garden gnomes that Brodie would need to paint to achieve this aim. (3)

Question 14**(9 marks)**

A piece of wire 8cm long is cut into two unequal parts. One part is used to form a rectangle that has a length three times its width. The other part of the wire is used to form a square.

- (i) If the width of the rectangle is x units, determine an equation that will give the sum of the areas of the rectangle and the square in terms of x .

(4)

- (ii) Using Calculus, find the length of each part of the wire when the sum of the areas is a minimum.

(5)

Question 15**(11 marks)**

Nuts and Bolts Company manufactures 120mm bolts which are normally distributed with a mean length of 120mm and a standard deviation of 1mm. Only bolts which are between 118.6mm and 121.4mm pass inspection and are packaged as 120mm bolts.

- (a) Find the probability of a randomly selected bolt being an acceptable length. (2)
- (b) Find the expected number of acceptable bolts in a batch of 100 000 (1)
- (c) Is this a reasonable outcome for the company? Justify your answer. (2)
- (d) A new quality controller suggests adjusting the settings on the machines so that the standard deviation becomes 0.85mm and that only the shortest 5% and the longest 5% of the bolts are rejected.
- (i) Find the new minimum and maximum acceptable lengths correct to the nearest 0.1mm. (3)
- (ii) Do the packages contain bolts that are more consistent in length? (1)
- (iii) Is the manufacturer better off? Justify. (2)

Question 16

(7 marks)

The graph of $g'(x)$ is given below.

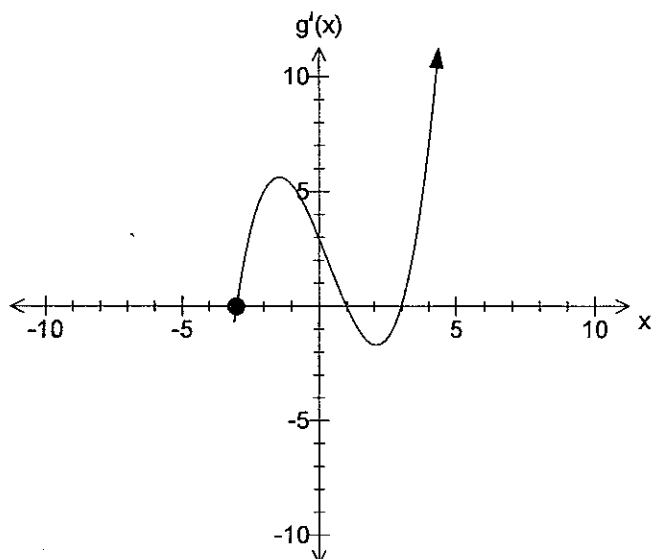

- (a) What can be said about the gradient of the function $g(x)$ between $x = -3$ to $x = 1$? (1)
- (b) When does the function, $g(x)$ have a negative gradient? (2)
- (c) State an equation for the tangent to the graph of $g(x)$ at $x = 3$. (1)
- (d) Find the value of x at which $g(x)$ has a relative maximum for $-3 \leq x \leq 4$ (1)
- (e) Find the x -coordinate of each point of inflection of the graph of $g(x)$ for $-3 \leq x \leq 4$ (2)

Question 17

(9 marks)

- (a) Find the area of the region bounded by the curves $y = x^3$ and $y = 3x + 2$ in the diagram.

Showing all working steps.

(4)

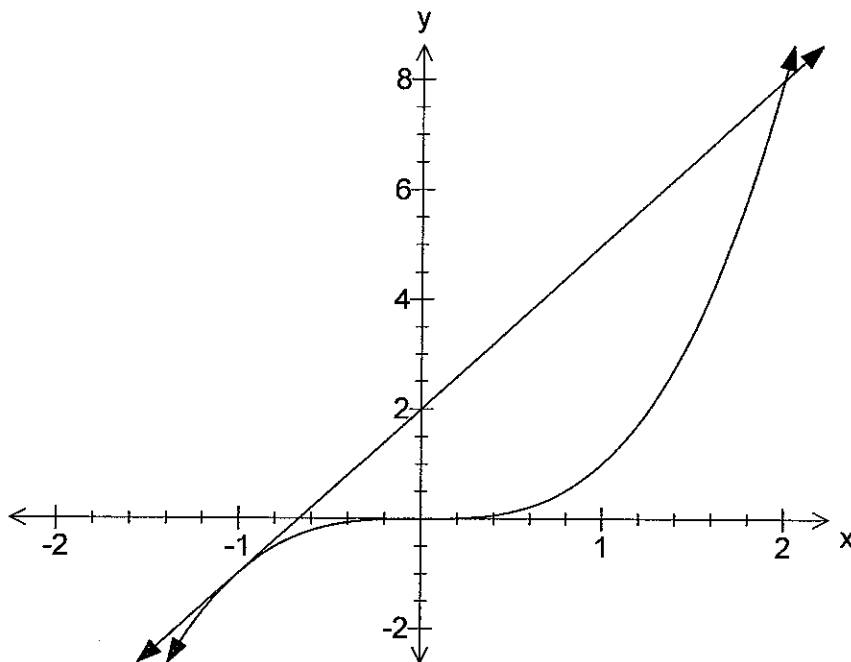

Question 17 (continued)

- (b) A group of anthropologists found that human tooth size is continuing to decrease, such that
- $$\frac{dS}{dt} = kS$$

In Northern Europeans, for example, it has been found that tooth size has reduced 1% in the last 1000 years and this trend is expected to continue.

- (i) If t represents time in years and S represents tooth size, find the value of k .

(2)

- (ii) In how many years will human tooth size be 90% of their present size?

(2)

- (iii) What will be our descendant's tooth size 20 000 years from now?

(1)

(as a percentage of our present tooth size)

Question 18

(6 marks)

(a) For the function $y = f(x)$ below

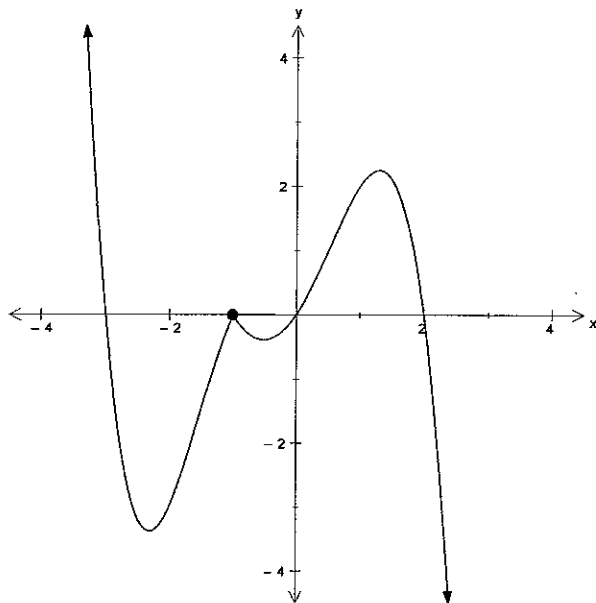

It is known that

$$\int_{-3}^{-1} f(x) dx = -75$$

$$\int_{-1}^2 f(x) dx = 20$$

The area under the curve from $x = -1$ to $x = 2$ is 80 square units.

Use the information above and mathematical reasoning to determine the value of each of the following.

(i) $\int_{-1}^0 f(x) dx$ (2)

(ii) the area between the curve and the x-axis from $x = -3$ to $x = 0$ (1)

Question 18 (continued)

(iii) $\int_{-3}^2 f(x) dx$ (1)

(b) The graph of a function $f(x)$ consists of a semi-circle and two line segments as shown.

Find the exact value of $\int_{-3}^4 f(x) dx$ (2)

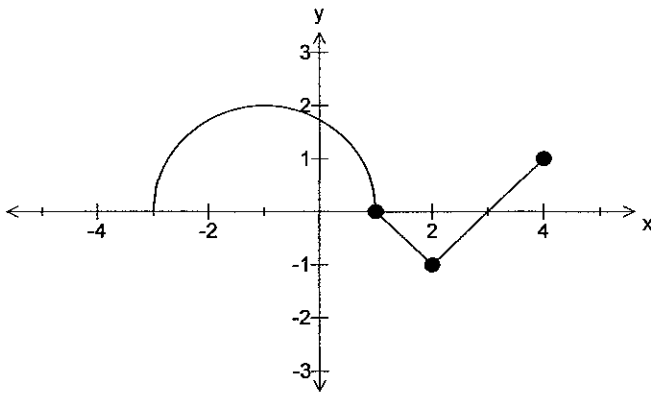

THIS PAGE HAS BEEN LEFT BLANK INTENTIONALLY